Datasheet

Apollo Display Technologies

G215HVN01.0(S03)-V559

21.5" High Brightness TFT Display

UP-02-088R1.1

The information contained in this document has been carefully researched and is, to the best of our knowledge, accurate. However, we assume no liability for any product failures or damages, immediate or consequential, resulting from the use of the information provided herein. Our products are not intended for use in systems in which failures of product could result in personal injury. All trademarks mentioned herein are property of their respective owners. All specifications are subject to change without notice.

Content

Revision History	3
1. Operating Precautions	4
2. General Description	5
2.1 Display Characteristics	5
2.2 Optical Characteristics	6
3. Functional Block Diagram	7
4. Absolute Maximum Ratings	8
4.1 Absolute Ratings of TFT LCD Module	8
4.2 Absolute Ratings of Backlight Unit	8
4.3 Absolute Ratings of Environment	8
5. Electrical Characteristics	10
5.1 TFT LCD Module	10
5.1.1 Power Specification	10
5.1.2 Signal Electrical Characteristics	11
5.2 Backlight Specification	12
6. Signal Characteristic	13
6.1 Pixel Format Image	13
6.2 Signal Description	14
6.3 The Input Data Format	15
6.4 Interface Timing	16
6.4.1 Timing Characteristics	16
6.4.2 Input Timing Diagram	16
6.5 Power ON/OFF Sequence	17
7. Connector & Pin Assignment	18
7.1 TFT LCD Module: LVDS Connector	18
8. Reliability Test	19
9. Mechanical Characteristics	20
10. Shipping Label	22

Revision History

Version and Date	Page	description											
1.0 2013/01/30	All	Preliminary edition											
2.0 2014/04/23	5	Physical size (D) changed											
3.0 2015/01/14	21 5, 8	New rear view drawing Operating temperature changed from 0...+50°C to 0...+60°C											
4.0 2015/02/10	14	<table border="1"> <tr> <td>15</td> <td>RXinE1-</td> <td>Negative LVDS differential data input (Even data)</td> </tr> <tr> <td>16</td> <td>RXinE1+</td> <td>Positive LVDS differential data input (Even data)</td> </tr> </table>	15	RXinE1-	Negative LVDS differential data input (Even data)	16	RXinE1+	Positive LVDS differential data input (Even data)					
	15	RXinE1-	Negative LVDS differential data input (Even data)										
	16	RXinE1+	Positive LVDS differential data input (Even data)										
	6	<table border="1"> <tr> <td>Green x</td> <td>0.253</td> <td>0.303</td> <td>0.353</td> </tr> </table>	Green x	0.253	0.303	0.353							
	Green x	0.253	0.303	0.353									
6	<table border="1"> <tr> <td>Raising Time (T_{rR})</td> <td>-</td> <td>20</td> <td>25</td> </tr> <tr> <td>Falling Time (T_{rF})</td> <td>-</td> <td>5</td> <td>10</td> </tr> <tr> <td>Raising + Falling</td> <td>-</td> <td>25</td> <td>35</td> </tr> </table>	Raising Time (T_{rR})	-	20	25	Falling Time (T_{rF})	-	5	10	Raising + Falling	-	25	35
	Raising Time (T_{rR})	-	20	25									
	Falling Time (T_{rF})	-	5	10									
Raising + Falling	-	25	35										
23	New front view drawing												
5.0 09.06.2015	1	New Version G215HVN01.0(S03)-V559 UP-02-088R1.1											
	5	Typ. brightness changed to 850cd/m ² Weight changed to 3460g Backlight Input Voltage changed to 41.3V Power consumption changed to VDD 4.4 + LED 36.1 = 40.5 (typ) Physical size (D) changed to 20.9mm											
	6	Luminance uniformity changed Central Luminance changed to min. 700 / typ. 850											
	7	LED Connector type changed											
	8	Max. LED input voltage changed to 48V											
	12	New backlight specification											
	13	New recommended backlight power supply											

1. Operating Precautions

- 1) Since front polarizer is easily damaged, pay attention not to scratch it.
- 2) Be sure to turn off power supply when inserting or disconnecting from input connector.
- 3) Wipe off water drop immediately. Long contact with water may cause discoloration or spots.
- 4) When the panel surface is soiled, wipe it with absorbent cotton or other soft cloth.
- 5) Since the panel is made of glass, it may break or crack if dropped or bumped on hard surface.
- 6) Since CMOS LSI is used in this module, take care of static electricity and insure human earth when handling.
- 7) Do not open or modify the Module Assembly.
- 8) In case if a Module has to be put back into the packing container slot after once it was taken out from the container, take it easily, or the TFT Module may be damaged.
- 9) At the insertion or removal of the Signal Interface Connector, be sure not to rotate nor tilt the Interface Connector of the TFT Module.
- 10) After installation of the TFT Module into an enclosure, do not twist nor bend the TFT Module even momentary. At designing the enclosure, it should be taken into consideration that no bending/twisting forces are applied to the TFT Module from outside. Otherwise the TFT Module may be damaged.
- 11) Small amount of materials having no flammability grade is used in the LCD module. The LCD module should be supplied by power complied with requirements of Limited Power Source (IEC60950 or UL1950), or be applied exemption.
- 12) Severe temperature condition may result in different luminance, response time and LED life time.
- 13) The data on this specification sheet is applicable when LCD module is placed in landscape position.
- 14) Continuous displaying fixed pattern may induce image sticking. It is recommended to use screen saver or shuffle content periodically if fixed pattern is displayed on the screen.

2. General Description

This specification applies to the 21.5 inch-wide Color TFT-LCD Module G215HVN01.0(S03)-V559. The display supports the Full HD - 1920(H) x 1080(V) screen format and 16.7M colors (RGB 8-bits data). All input signals are dual channel LVDS interface.

G215HVN01.0-V559 is designed for industrial display applications.

2.1 Display Characteristics

The following items are characteristics summary on the table under 25°C condition:

ITEMS	Unit	SPECIFICATIONS
Screen Diagonal	[mm]	546.86(21.53")
Active Area	[mm]	476.64 (H) x 268.11 (V)
Pixels H x V		1920(x3) x 1080
Pixel Pitch	[um]	248.25 (per one triad) x248.25
Pixel Arrangement		R.G.B. Vertical Stripe
Display Mode		VA Mode, Normally Black
White Luminance (Center)	[cd/m ²]	850 (Typ.)
Contrast Ratio		5000 (Typ.)
Optical Response Time	[msec]	25 ms (Typ., on/off)
Nominal Input Voltage VDD	[Volt]	+5.0 V
Backlight Input Voltage	[Volt]	+41.3 V
Power Consumption (VDD line + LED line)	[Watt]	VDD: 4.4 + LED: 36.1 = 40.5 (Typ.) (all white pattern)
Weight	[Grams]	3460 (max.)
Physical Size	[mm]	495.6(W) x 292.2(H) x 20.9(D) Max.
Electrical Interface		Dual channel LVDS
Support Color		16.7M colors (RGB 8 bits)
Surface Treatment		Anti-Glare, 3H
Temperature Range		
Operating	[°C]	0 to +60
Storage (Shipping)	[°C]	-20 to +60
RoHS Compliance		RoHS Compliance
TCO Compliance		TCO 5.1 Compliance

2.2 Optical Characteristics

The optical characteristics are measured under stable conditions at 25°C (Room Temperature)

Item	Unit	Conditions	Min.	Typ.	Max.
Viewing Angle	[degree]	Horizontal (Right)	150	178	-
		CR = 10 (Left)			-
		Vertical (Up)	150	178	-
		CR = 10 (Down)			-
Contrast ratio		Normal Direction	3000	5000	-
Response Time	[msec]	Raising Time (T_{rR})	-	20	25
		Falling Time (T_{rF})	-	5	10
		Raising + Falling	-	25	35
Color / Chromaticity Coordinates (CIE)		Red x	0.589	0.639	0.689
		Red y	0.283	0.333	0.383
		Green x	0.253	0.303	0.353
		Green y	0.573	0.623	0.673
		Blue x	0.105	0.155	0.205
		Blue y	0.000	0.048	0.098
Color Coordinates (CIE) White		White x	0.263	0.313	0.363
		White y	0.279	0.329	0.379
Central Luminance	[cd/m ²]		700	850	-
Luminance Uniformity	[%]		70	75	-
Crosstalk (in 60Hz)	[%]				1.5
Flicker	dB				-20

3. Functional Block Diagram

The following diagram shows the functional block of this model:

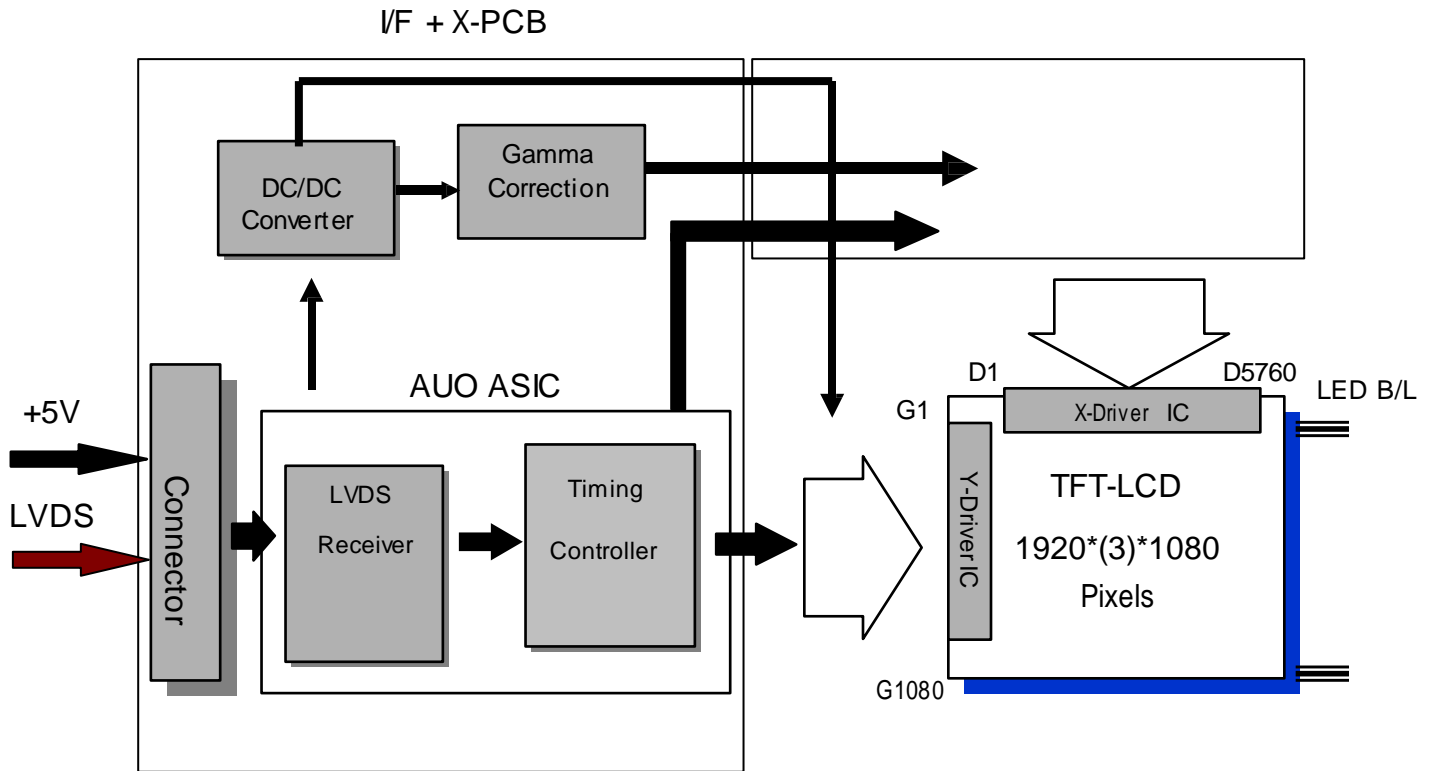

LVDS Connector: JAE (FI-XB30SRL-HF11) or equivalent.

LED Connector: CVILUX / CI1406M1HRC-NH Mating Housing: CVILUX / CI1406S0000-NH

4. Absolute Maximum Ratings

4.1 Absolute Ratings of TFT LCD Module

Item	Symbol	Min	Max	Unit	Conditions
Logic/LCD Drive Voltage	VDD	0	5.5	[Volt]	Note 1,2

4.2 Absolute Ratings of Backlight Unit

Item	Symbol	Min	Max	Unit	Conditions
LED Input Voltage	VLED	-	48	[Volt]	Note 1,2

4.3 Absolute Ratings of Environment

Item	Symbol	Min.	Max.	Unit	Conditions
Operating Temperature	TOP	0	+60	[°C]	Note 3
Glass Surface Temperature (Operation)	TGS	0	+65	[°C]	Note 3, Note 4
Operation Humidity	HOP	5	90	[%RH]	Note 3
Storage Temperature	TST	-20	+60	[°C]	
Storage Humidity	HST	5	90	[%RH]	

Note 1: With in Ta (25°C)

Note 2: Permanent damage to the device may occur if exceeding maximum values

Note 3: For quality performance, please refer to AUO IIS(Incoming Inspection Standard).

1. 90% RH Max (Ta ≤39°C)

2. Max wet-bulb temperature at 39°C or less. (Ta ≤39°C)

3. No condensation.

Note 4: Function judge only.

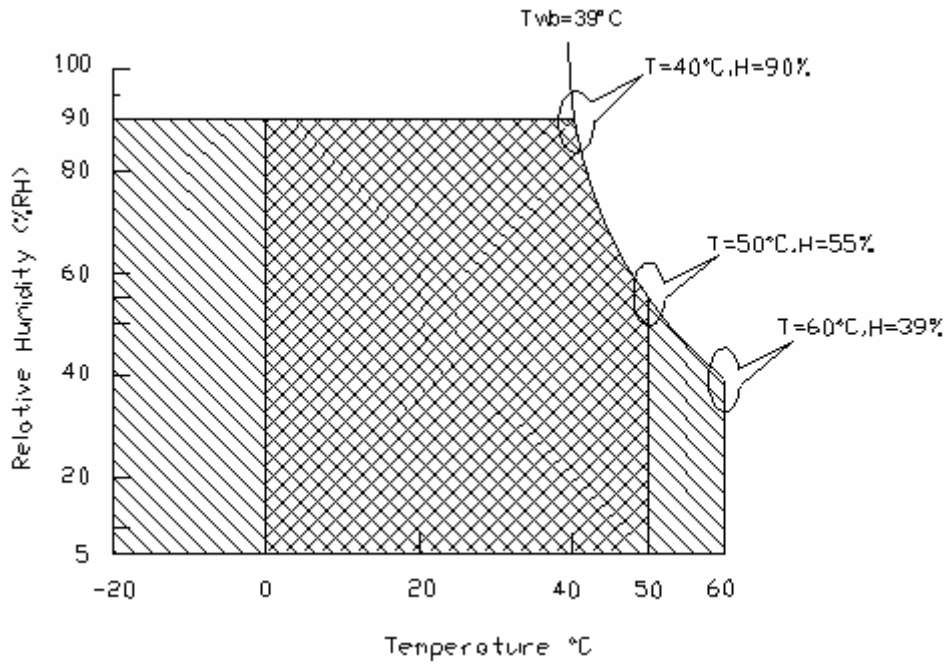

Operating Range  Storage Range  + 

5. Electrical Characteristics

5.1 TFT LCD Module

5.1.1 Power Specification

Symbol	Parameter	Min	Typ	Max	Unit	Conditions
VDD	Logic/LCD Drive Voltage	4.5	5.0	5.5	[Volt]	+/-10%
IDD	Input Current	-	0.7	0.8	[A]	VDD= 5.0V, All white pattern, At 60Hz
		-	0.81	0.89	[A]	VDD= 5.0V, All white pattern At 75Hz,
PDD	VDD Power	-	3.5	4.4	[Watt]	VDD= 5.0V, All white pattern, At 60Hz
		-	4.05	4.9	[Watt]	VDD= 5.0V, All white pattern At 75Hz,
IRush	Inrush Current	-	-	3	[A]	Note 1
VDDrp	Allowable Logic/LCD Drive Ripple Voltage	-	-	500	[mV] p-p	VDD= 5.0V, All white Pattern At 75Hz

Note 1: Measurement conditions:
The duration of rising time of power input is 470us.

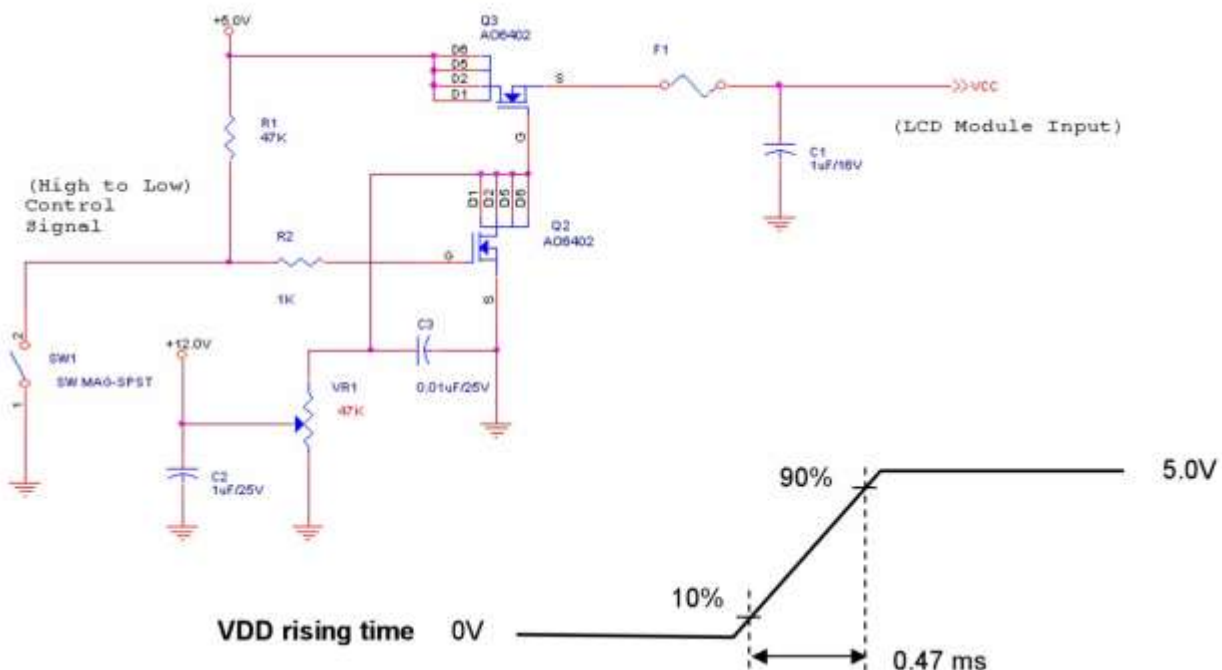

5.1.2 Signal Electrical Characteristics

Input signals shall be low or Hi-Z state when VDD is off.

Please refer to specifications of SN75LVDS82DGG (Texas Instruments) in detail.

Symbol	Parameter	Min	Typ	Max	Units	Condition
V_{TH}	Differential Input High Threshold	-	-	+100	[mV]	$V_{CM} = 1.2V$, Note 1
V_{TL}	Differential Input Low Threshold	-100	-	-	[mV]	$V_{CM} = 1.2V$ Note 1
$ V_{ID} $	Input Differential Voltage	100	-	600	[mV]	Note 1
V_{CM}	Differential Input Common Mode Voltage	+1.0	+1.2	+1.5	[V]	$V_{TH}-V_{TL} = 200MV$ (max) Note 1

Note 1: LVDS Signal Waveform

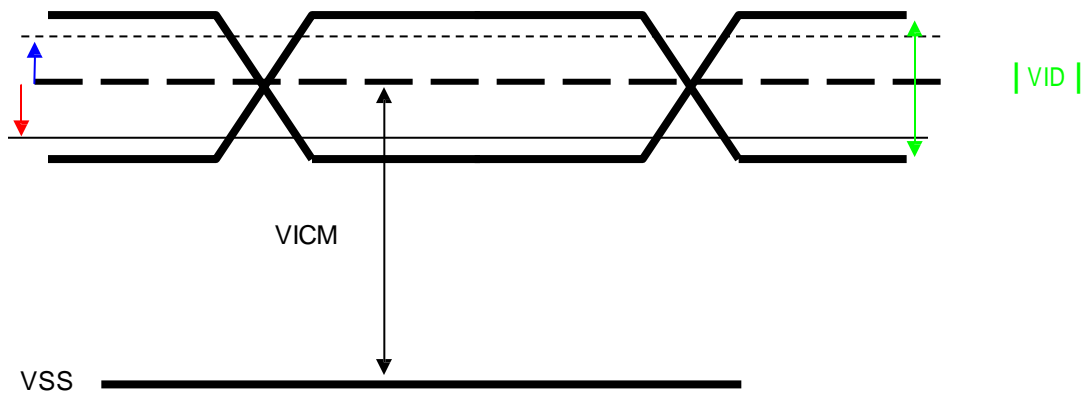

5.2 Backlight Specification

Apollo LED Backlight Unit (BLU)		133000-4				
		T _a = 25 ± 2°C				
Parameter	Symbol	Min.	Typ.	Max.	Unit	Note
BLU Input Voltage	V _f	-	45.1	45.3	V _{DC}	4,6
BLU Forward Current (per channel)	I _f	-	200	210	mA _{DC}	2,3,5
BLU Channels	-	-	4	-	-	-
BLU Power Consumption	P _{LED}	-	36.1	38.1	W	1,2
BLU Lifetime	L _L	-	100,000	-	hrs	1

Notes:

- (1) The lifetime of the LED BLU is defined as the number of hours it continues to operate at T_a = 25 ± 2°C and I_f = 200mA_{DC} until the luminance is 50% of its original value. Operating the BLU at T_a > 25 ± 2°C or applying power > 36.1W will reduce the lifetime and cause color shifting.
- (2) Specified values are for a single LED channel, this module contains four channels.
- (3) Specified current equals input to a single LED channel at 100% duty cycle.
- (4) Specified voltage is input to LED BLU at typical and maximum current values & 100% duty cycle.
- (5) It is recommended to dim LED BLU using PWM and to synchronize PWM with frame frequency.
- (6) $V_f = \Delta_{BLU}^{BLU0}(V_A - V_C)$

Connector Name	LED BLU Connector
Connector Manufacturer P/N	CVILUX CI1406M1HRC-NH
Connector Mate	CVILUX CI1406S0000-NH

LED BLU CONN. PIN ASSIGNMENT		
Pin	Name	Signal
1	C1	Cathode 1
2	C2	Cathode 2
3	AN	Common Anode
4	AN	Common Anode
5	C3	Cathode 3
6	C4	Cathode 4

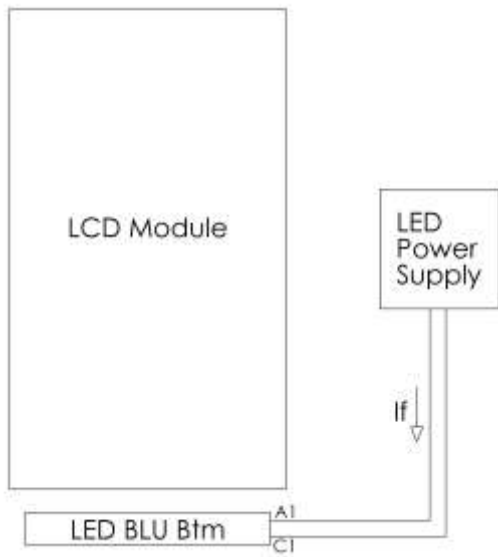

Recommended backlight power supply

PART NUMBER		MANUFACTURER
LED Converter		Distec GmbH
PWM Dimming:	IN-54-002 SmartLEDIV-002	
Cable	KA-25-014 CBL-LED-SL4-12 305mm	

6. Signal Characteristic

6.1 Pixel Format Image

Following figure shows the relationship of the input signals and LCD pixel format.

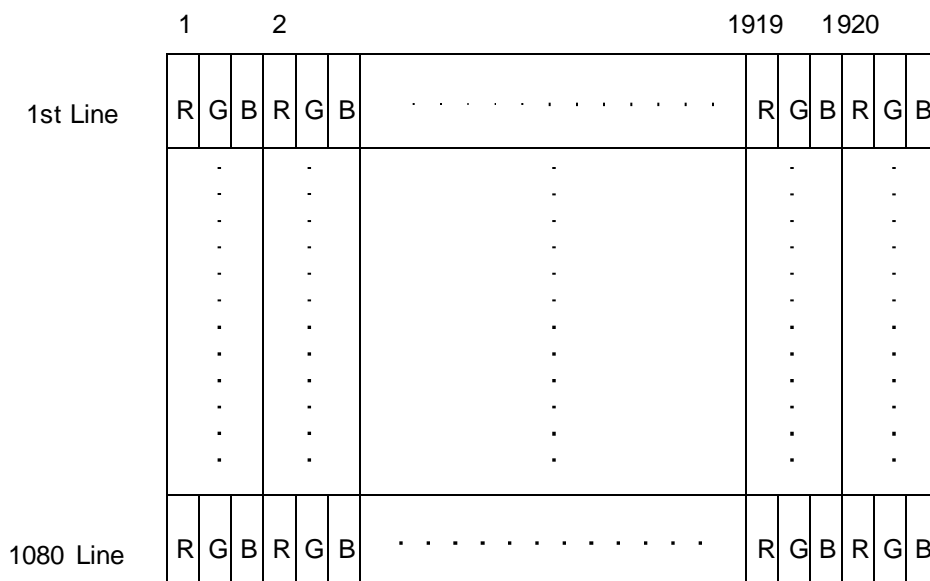

6.2 Signal Description

The module using a pair of LVDS receiver SN75LVDS82 (Texas Instruments) or compatible. LVDS is a differential signal technology for LCD interface and high speed data transfer device. Transmitter shall be SN75LVDS83 (negative edge sampling) or compatible. The first LVDS port (RxOxxx) transmits odd pixels while the second LVDS port (RxExxx) transmits even pixels.

PIN #	SIGNAL NAME	DESCRIPTION
1	RXinO0-	Negative LVDS differential data input (Odd data)
2	RXinO0+	Positive LVDS differential data input (Odd data)
3	RXinO1-	Negative LVDS differential data input (Odd data)
4	RXinO1+	Positive LVDS differential data input (Odd data)
5	RXinO2-	Negative LVDS differential data input (Odd data, H-Sync, V-Sync,
6	RXinO2+	Positive LVDS differential data input (Odd data, H-Sync, V-Sync,
7	GND	Power Ground
8	RxOCLKIN-	Negative LVDS differential clock input (Odd clock)
9	RxOCLKIN+	Positive LVDS differential clock input (Odd clock)
10	RXinO3-	Negative LVDS differential data input (Odd data)
11	RXinO3+	Positive LVDS differential data input (Odd data)
12	RXinE0-	Negative LVDS differential data input (Even data)
13	RXinE0+	Positive LVDS differential data input (Even data)
14	GND	Power Ground
15	RXinE1-	Negative LVDS differential data input (Even data)
16	RXinE1+	Positive LVDS differential data input (Even data)
17	GND	Power Ground
18	RXinE2-	Negative LVDS differential data input (Even data)
19	RXinE2+	Positive LVDS differential data input (Even data)
20	RxECLKIN-	Negative LVDS differential clock input (Even clock)
21	RxECLKIN+	Positive LVDS differential clock input (Even clock)
22	RXinE3-	Negative LVDS differential data input (Even data)
23	RXinE3+	Positive LVDS differential data input (Even data)
24	GND	Power Ground
25	NC	No connection (for AUO test only. Do not connect)
26	NC	No connection (for AUO test only. Do not connect)
27	NC	No connection (for AUO test only. Do not connect)
28	VDD	Power +5V
29	VDD	Power +5V
30	VDD	Power +5V

6.3 The Input Data Format

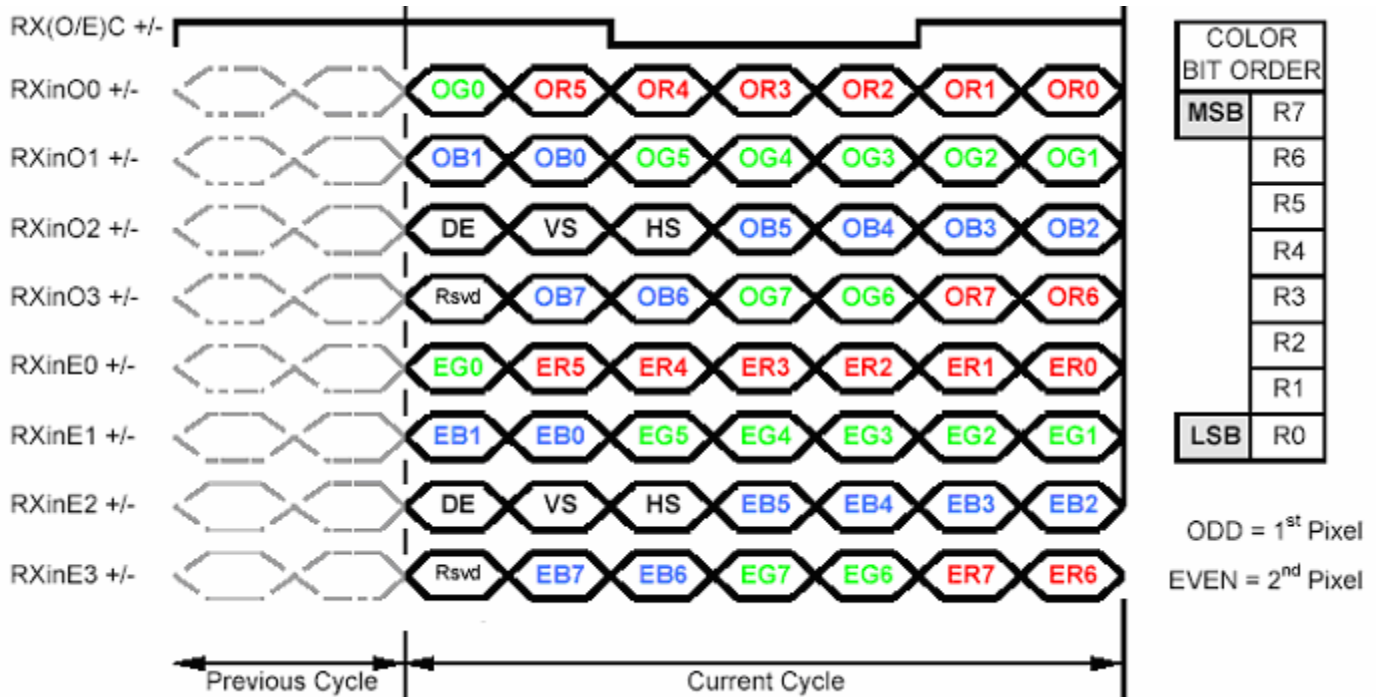

Note1: 8-bits signal input.

Note2: L:NS alike H:Thine alike

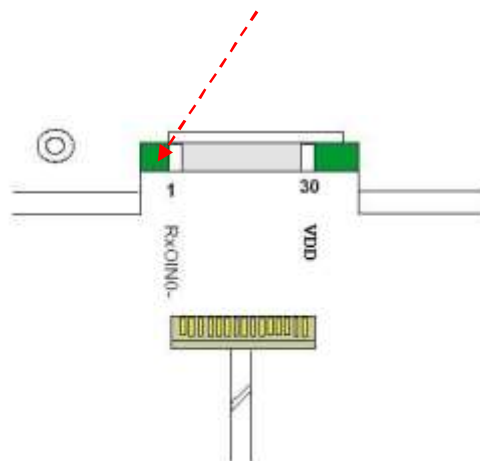

6.4 Interface Timing

6.4.1 Timing Characteristics

Signal	Item	Symbol	Min	Typ	Max	Unit
Clock	Frequency	$1/T_{\text{Clock}}$	40	72	83	MHz
Frame Rate	Frequency	$1/T_V$	50	60	75	Hz
Vertical Section	Period	T_V	1088	1120	2047	T_line
	Active	T_{VD}	1080	1080	1080	
	Blanking	T_{VB}	8	40	967	
Horizontal Section	Period	T_H	1034	1060	2047	T_clock
	Active	T_{HD}	960	960	960	
	Blanking	T_{HB}	74	100	1087	

Note: DE mode only.

6.4.2 Input Timing Diagram

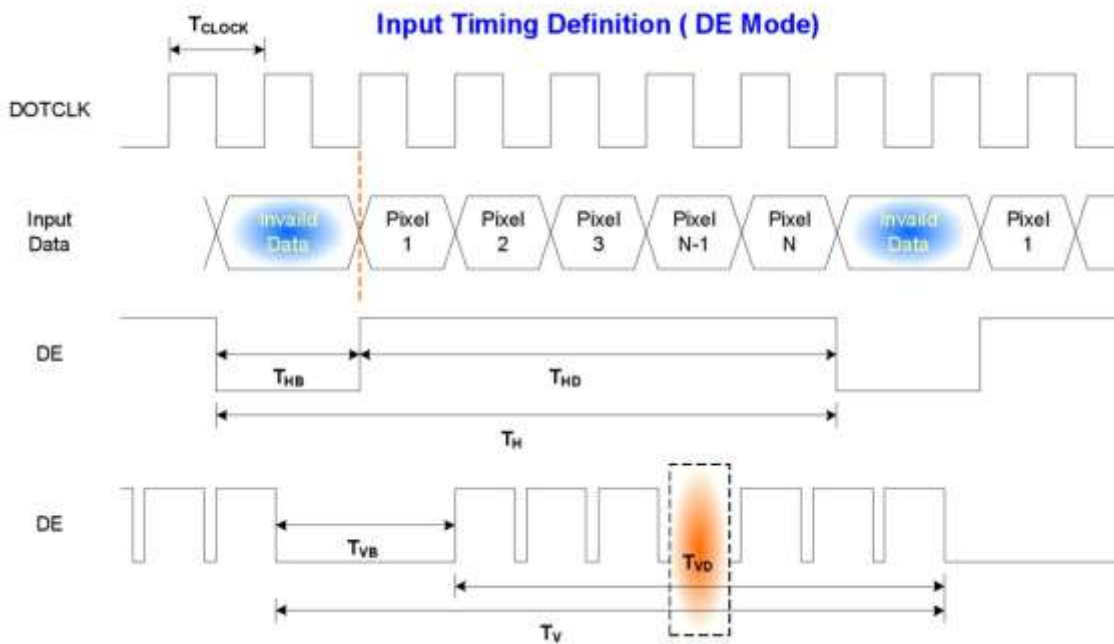

6.5 Power ON/OFF Sequence

VDD power and B/L on/off sequence is as below. Interface signals are also shown in the chart. Signals from any system shall be Hi-Z state or low level when VDD is off.

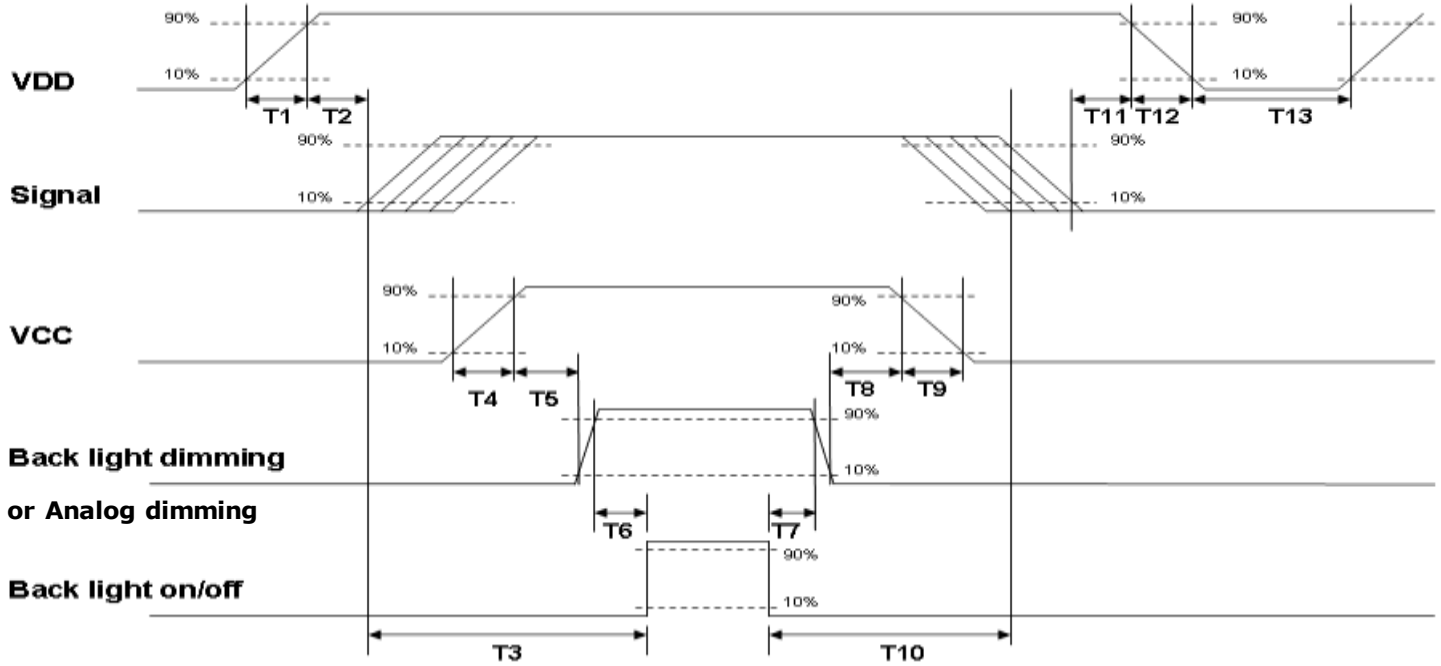

Power ON/OFF sequence timing

Parameter	Value			Units
	Min.	Typ.	Max.	
T1	0.5	--	10	[ms]
T2	30	40	50	[ms]
T3	200	--	--	[ms]
T4	0.5	--	10	[ms]
T5	10	--	--	[ms]
T6	10	--	--	[ms]
T7	0	--	--	[ms]
T8	10	--	--	[ms]
T9	--	--	10	[ms]
T10	110	--	--	[ms]
T11	0	16	50	[ms]
T12	--	--	10	[ms]
T13	1000	--	--	[ms]

The above on/off sequence should be applied to avoid abnormal function in the display. Please make sure to turn off the power when you plug the cable into the input connector or pull the cable out of the connector.

7. Connector & Pin Assignment

Physical interface is described as for the connector on module. These connectors are capable of accommodating the following signals and will be following components.

7.1 TFT LCD Module: LVDS Connector

Connector Name / Designation	Interface Connector / Interface card
Manufacturer	JAE or compatible
Type Part Number	JAE (FI-XB30SRL-HF11) or equivalent.
Mating Housing Part Number	FI-X30HL (JAE) or compatible

Pin#	Signal Name	Pin#	Signal Name
1	RxOIN0-	2	RxOIN0+
3	RxOIN1-	4	RxOIN1+
5	RxOIN2-	6	RxOIN2+
7	GND	8	RxOCLKIN-
9	RxOCLKIN+	10	RxOIN3-
11	RxOIN3+	12	RxEIN0-
13	RxEIN0+	14	GND
15	RxEIN1-	16	RxEIN1+
17	GND	18	RxEIN2-
19	RxEIN2+	20	RxECLKIN-
21	RxECLKIN+	22	RxEIN3-
23	RxEIN3+	24	GND
25	NC	26	NC
27	NC	28	VDD
29	VDD	30	VDD

8. Reliability Test

Environment test conditions are listed as following table.

Items	Required Condition	Note
Temperature Humidity Bias (THB)	Ta= 50°, 80%RH, 300 hours	
High Temperature Operation (HTO)	Ta= 50°, 50%RH, 300 hours	
Low Temperature Operation (LTO)	Ta= 0°, 300 hours	
High Temperature Storage (HTS)	Ta= 60°, 300 hours	
Low Temperature Storage (LTS)	Ta= -20°, 300 hours	
Vibration Test (Non-operation)	Acceleration: 1.5 Grms Wave: Random Frequency: 10 - 200 Hz Duration: 30 Minutes each Axis (X, Y, Z)	
Shock Test (Non-operation)	Acceleration: 50 G Wave: Half-sine Active Time: 20 ms Direction: ±X, ±Y, ±Z (one time for each Axis)	
Drop Test	Height: 46 cm, package test	
Thermal Shock Test (TST)	-20°/30min, 60°/30min, 100 cycles	1
On/Off Test	On/10sec, Off/10sec, 30,000 cycles	
ESD (Electro Static Discharge)	Contact Discharge: ± 8KV, 150pF(330Ω) 1sec, 15 points, 25 times/ point.	2
	Air Discharge: ± 15KV, 150pF(330Ω) 1sec 15 points, 25 times/ point.	
Altitude Test	Operation:10,000 ft Non-Operation:30,000 ft	

Note 1: The TFT-LCD module will not sustain damage after being subjected to 100 cycles of rapid temperature change. A cycle of rapid temperature change consists of varying the temperature from -20°C to 60°C, and back again. Power is not applied during the test. After temperature cycling, the unit is placed in normal room ambient for at least 4 hours before power on.

Note2: According to EN61000-4-2, ESD class B: Some performance degradation allowed. No data lost Self-recoverable. No hardware failures.

9. Mechanical Characteristics

Please refer to the following page

REVISION HISTORY		DATE
REV	DESCRIPTION	
0	Initial	9/21/2015

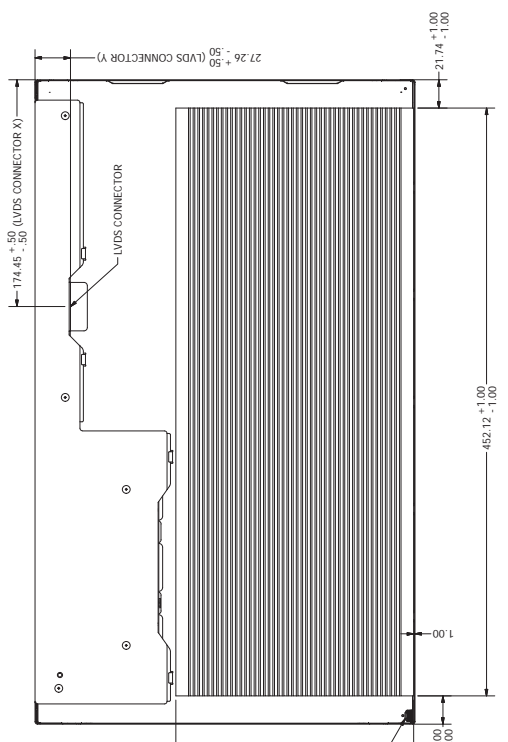
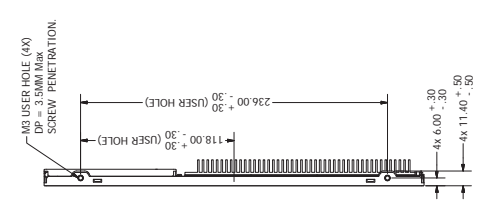
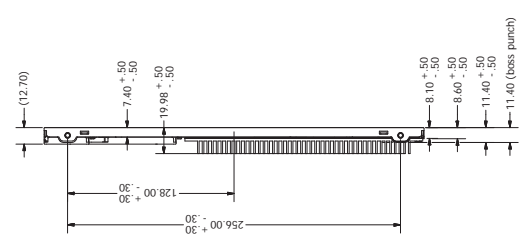
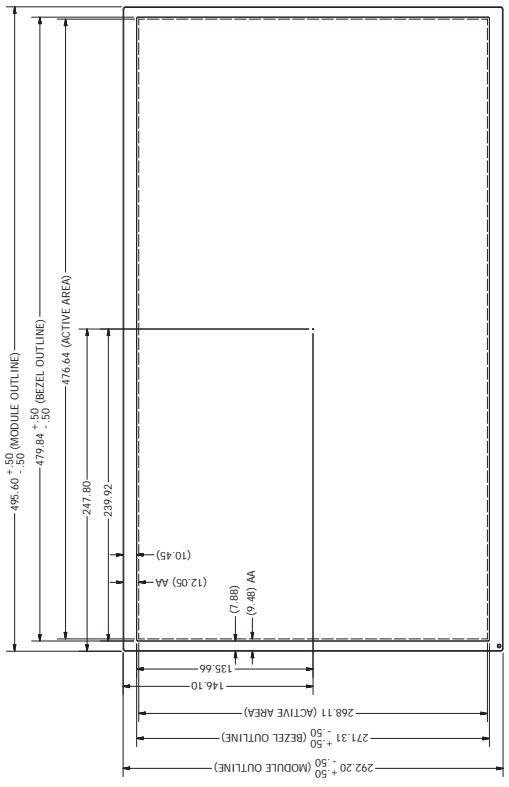

LED BLU CONNECTOR

PROPRIETARY AND CONFIDENTIAL

THE INFORMATION CONTAINED IN THIS DRAWING IS THE SOLE PROPERTY OF APOLLO DISPLAY TECHNOLOGIES, CORP. ANY REPRODUCTION IN PART OR AS A WHOLE WITHOUT THE WRITTEN PERMISSION OF APOLLO DISPLAY TECHNOLOGIES, CORP. IS PROHIBITED.

DRAWN	5/20/2015	Apollo Display Technologies, Corp.	
DESIGNED	5/20/2015	100% Reel's Compliant	
ALL		TITLE	
OK		ASSY MODULE UP-02-088R1.1	
MFG		SIZE	D
APPROVED		DWG NO	UP-02-088R1.1
		REV	0
		SCALE	1:1
		DO NOT SCALE DRAWING	

- NOTES:
1. PRELIMINARY DRAWING FOR REFERENCE ONLY
 2. THESE DIMENSIONS EXCLUDE DEFORMATION
 3. UNSPECIFIED TOLERANCE +/- 0.5mm
 4. TORQUE OF M3 USER HOLE SHOULD BE WITHIN 4 KGF-CM AND RE-SCREW 10 TIMES.
 5. MODULE THICKNESS SHOULD BE 1.4MM MAX (EXCLUDING REAR AFFIXED HEAT-SINK)
 6. USER HOLE SCREW PENETRATION 3.5mm MAX.

10. Shipping Label

The label is on the panel as shown below:

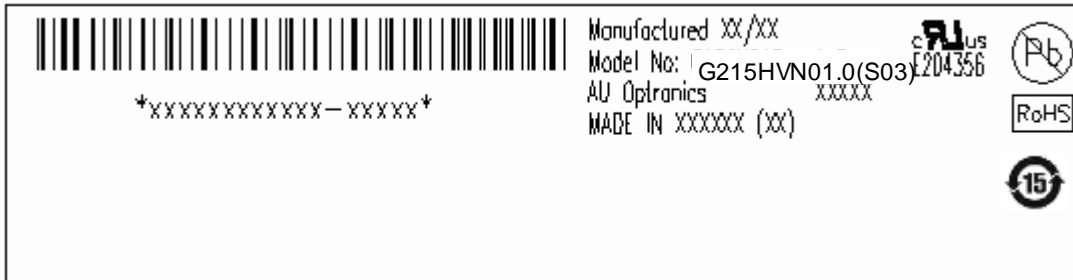

-V559

Our company network supports you worldwide with offices in Germany, Austria, Switzerland, Great Britain and the USA. For more information please contact:

Headquarters

Germany



FORTEC Elektronik AG
Lechwiesenstr. 9
86899 Landsberg am Lech

Phone: +49 8191 91172-0
E-Mail: sales@forteca.de
Internet: www.forteca.de

Fortec Group Members

Austria



FORTEC Elektronik AG
Office Vienna

Nuschinggasse 12
1230 Wien

Phone: +43 1 8673492-0
E-Mail: office@fortec.at
Internet: www.fortec.at

Germany



Distec GmbH

Augsburger Str. 2b
82110 Germering

Phone: +49 89 894363-0
E-Mail: info@distec.de
Internet: www.distec.de

Switzerland



ALTRAC AG

Bahnhofstraße 3
5436 Würenlos

Phone: +41 44 7446111
E-Mail: info@altrac.ch
Internet: www.altrac.ch

Great Britain



Display Technology Ltd.

5 The Oaks Business Village
Revenge Road, Lordswood
Chatham, Kent, ME5 8LF

Phone: +44 1634 62755
E-Mail: info@displaytechnology.co.uk
Internet: www.displaytechnology.co.uk

USA



Apollo Display Technologies, Corp.

87 Raynor Avenue,
Unit 1 Ronkonkoma,
NY 11779

Phone: +1 631 5804360
E-Mail: info@apolloDisplays.com
Internet: www.apolloDisplays.com